



Food & Beverage

Facility Coatings

All coating systems are not created equal

Their physical and performance characteristics are varied, making it important to select the system that will meet the demands of specific areas within a food and beverage facility.

Chemical resistance and thermal shock are common challenges within these facilities that can prematurely age a system or cause coating failure, while slip resistance and cleanability can impact employee and product safety.

NEOGARD® manufactures a variety of high performance coating solutions to withstand the demanding environments in the food and beverage market as well as coatings to protect the remainder of the building envelope.

We have coating solutions for the whole Food & Beverage industry including:

- Bakery
- Meat & Fish
- Freezers & Cold Storage
- Beverage & Bottle Lines
- Kitchen & Production Lines



Advanced coating technology

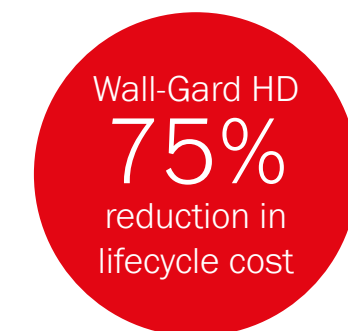

Wall-Gard HD

Wall-Gard HD is a high-performance wall coating system with an optional fabric reinforcement for added protection against impacts from carts, material handling equipment and rolling racks.

Its exceptional scrub and chemical resistance make it ideal for environments where maintaining a sanitary work environment is essential.

With a durability four-times greater than standard interior paint, facilities can achieve a 75% reduction in lifecycle cost by extending repaint cycles and reducing the facilities out-of-service time.

Typical applications

System 1 for Concrete or Block Walls

This basic system is highly durable with low odor and VOC, as well as exceptional scrub and chemical resistance.

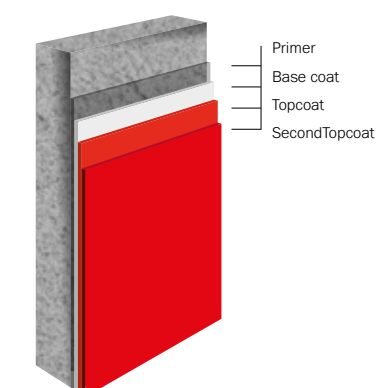

System 2 with Fiberglass Reinforcement for Drywall

Incorporating fiberglass mesh into the system makes it ideal for high traffic areas where walls may be subject to impact abuse.

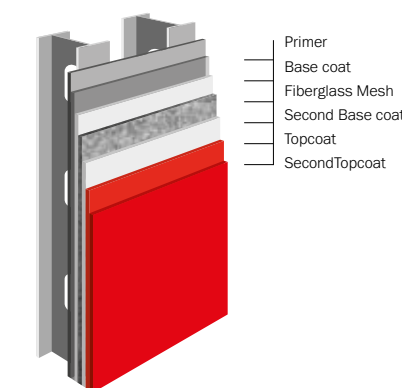

Neocrete

Neocrete is a cementitious polyurethane floor coating system ideal for the demanding environments found within a food and beverage facility.

Neocrete has increased impact, wear, and abrasion resistance that stands up to heavy machinery and equipment used within those facilities. Its exceptional chemical resistance and thermal shock tolerance exceeds the requirements for flooring protection and cleanability.

Neocrete's fast return to service allows for shorter facility downtime and the system can be installed under a wide range of temperatures and environments, including over quarry tile and damp concrete.

Typical applications

System 1 for Floors

A neat or broadcast system provides excellent resistance to aggressive chemicals, abrasion, heavy impacts, and is formulated to withstand thermal shock stresses, such as hot water and daily steam cleaning.

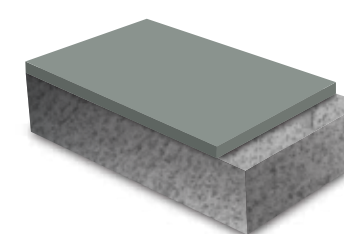

System 2 for Decorative Floors

A decorative flake or quartz broadcast and high solids CRU topcoat over Neocrete provides excellent resistance to aggressive chemicals, abrasion and impacts while providing slip resistance and a decorative finish.

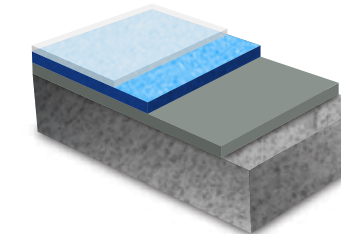

The high performance you need



Seamless floor to ceiling protection



Bakeries

Bakery walls can be subject to impacts from carts and racks. With Wall-Gard HD, facilities can protect their walls while also providing a durable and cleanable surface. Bakery floors are exposed to flour, eggs, sugars, oil and yeast, providing all of the ingredients for a tasty treat but also a potentially hazardous environment for employee slips and falls. Bakery flooring solutions require a system that can handle heavy duty cleaning with aggressive chemicals while also resisting staining and thermal shock. Using Wall-Gard HD and Neocrete with a cove transition, facilities can provide seamless floor to ceiling protection.

Meat & fish

Meat and fish processing areas are constantly challenged by the aggressive cleaning products required for areas exposed to blood, grease, and oils. Floors must also provide adequate slip resistance for employee safety. A combined seamless Wall-Gard HD and Neocrete application provides the best protection while maintaining a sanitary and safe working environment.

Freezers & cold storage

Freezers and cold storage rooms require flooring solutions that can be installed in environments with lower temperatures and can closely match the contraction and expansion properties of the concrete substrate without failing in extreme temperatures. Neocrete is the ideal flooring solution for those extreme cold environments.

Beverage & bottle lines

Beverage and bottling line floors and walls are constantly exposed to mechanical vibrations, heavy duty cleaning products, spills, and impacts. The combination of Neocrete and Wall-Gard HD will provide seamless protection and a safe and sanitary work environment.

Kitchens & production lines

Kitchens and production lines are at the heart of many food processing facilities. With daily exposure to oil, grease, and heavy duty cleaning products the flooring system used must be capable of withstanding thermal cycling and the rigorous cleaning required to maintain a sanitary and safe slip resistant environment.

Total coatings solutions

Building envelope

NEOGARD® products offer coating system solutions for the building envelope through vehicular and pedestrian traffic coatings, protective roof coatings, seamless flooring, and elastomeric wall coatings.

High performance coating solutions that withstand demanding environments

Industrial flooring systems

Neocrete SL or SL Broadcast	Self-level grade cement based water dispersed polyurethane mortar in smooth or with broadcast for texture.
Neocrete Trowel	Trowel grade cement based water dispersed polyurethane mortar.
Novolac 32	Superior chemical-resistant, 100%-solids Novolac epoxy system with optional texture coat.
Novolac 125	Heavy duty, superior chemical-resistant, 100%-solids Novolac epoxy system with optional texture coat.
KitchenGard 3/16"	Epoxy resin system with slurry base coats, quartz aggregate and Novolac epoxy seal coats.

Decorative flooring systems

Neocrete SL Flake	Self-level grade cement based water dispersed polyurethane mortar with texture and decorative flake finish.
Neocrete SL Quartz	Self-level grade cement based water dispersed polyurethane mortar with texture and decorative quartz finish.
Neoflake	Thin film, 100% solids epoxy system with PVC flakes.
NeoQuartz Broadcast	100% solids, epoxy broadcast system with quartz.
NeoQuartz Trowel	100% solids, epoxy trowel system with quartz.

Wall coating systems

Wall-Gard HD	Cleanable and durable, urethane and epoxy wall & ceiling coating system.
Neoflex	Elastomeric, 100% acrylic, anti-carbonation wall coating to waterproof concrete, stucco, EIFS and masonry surfaces.
Neocrylic	100% acrylic, anti-carbonation coating for exterior concrete, stucco, EIFS and masonry.
Neocrylic HB	High-build, 100% acrylic, anti-carbonation coating for exterior concrete, stucco, EIFS and masonry.
Neocrylic LR	Light reflective, acrylic coating for interior garage and corridor ceilings, walls and columns.

Fluid-applied roof coating systems

Acrylithane HS2	Acrylic urethane for lasting color over metal roofs and other metal surfaces.
Elasta-Gard M	Aliphatic urethane system for use over metal surfaces.
Elastacryl M	Acrylic system for use over metal surfaces.
Elasta-Gard C	Aliphatic urethane system for use over concrete surfaces.
Elasta-Gard SP	Aliphatic urethane system for use over single ply membranes such as TPO, PVC, EPDM, etc.
Elastacryl SP	Acrylic system for use over single ply membranes such as TPO, PVC, EPDM, etc.
Elasta-Gard BUR/MB	Aliphatic urethane system for use over smooth surfaced BUR/MB or granulated cap sheet.
Elastacryl BUR/MB	Acrylic system for use over smooth surfaced BUR/MB or granulated cap sheet.



“Our washout area floors have been given new life! We are incredibly pleased with the Wall-Gard HD & Neocrete applications and results!”

Brad Boness - Mountain Man Nut & Fruit Co.

Selected projects

Project	Location	Application	Year
Syracuse University Life Sciences Cafeteria	Syracuse, NY	Neocrete SL Quartz	2018
Mountain Man Nut & Fruit Company	Parker, CO	Neocrete SL and fabric reinforced Wall-Gard HD	2017
Pepsi, Co. Dry Goods Distribution Center	Panama Pacifico, Panama	35,000 sf of CG-65	2017
Harvest Meats Bacon & Sausage Plant	Saskatchewan, Canada	14,000 sf of Neocrete SL	2016
PepsiCo	Arlington, TX	130,000 sf Permathane II	2015
Marriott Gateway Kitchens	Atlanta, GA	Neocrete SL Broadcast with a Novolac Top coat system	2014
Pat O'Brien's	Destin, FL	6,200 sf of Permathane II FR	2008
Maple Leaf Foods Bacon Plant	Saskatchewan, Canada	20,000 sf of Neocrete SL	2005
Coca-Cola Foods	Oakland, CA	Neocrete SL	2004
Maple Leaf Foods Weiner & Sausage Plant	Saskatchewan, Canada	110,000 sf of Neocrete SL	2001
CanGro Foods Canola Oil Plant	Saskatchewan, Canada	10,000 sf of Neocrete SL	2001



NEOGARD®, a Division of Hempel (USA), Inc., is a fully integrated research and manufacturing organization in Dallas, Texas. NEOGARD® products have been specified and used on prestigious projects around the world by leading architects, engineers and consultants for over 50 years. Our line of coating systems protects the building envelope through vehicular and pedestrian traffic coatings, protective roof coatings, seamless flooring and elastomeric wall coatings.

NEOGARD Headquarters
2728 Empire Central, Dallas, TX 75235
Tel: +1 (214) 353-1600
Fax: 214-353-1766

www.neogard.com

NEOGARD®, A Division of Hempel (USA), Inc.

US_V1_MAR_18